



GrimmSpeed 3 Port Boost Control Solenoid

Installation Instructions

2002+ Subaru WRX/STi/LGT/FXT



All GrimmSpeed products are intended for Off-Road use only.

Park your vehicle on a level surface. Fully engage the parking brake and put wheel stops on the front and rear wheels to keep the vehicle from rolling.

Warning (read before installing):

Before moving forward with the setups outlined below, insure that you have the experience and confidence to properly tune your car. If not, please consult a tuning professional. Without a proper tune you can overboost and damage your engine.

Under no circumstances is the GrimmSpeed Solenoid to be used in any applications where failure of the valve to operate as intended could jeopardize the safety of the operator or any other person or property.

Note! You must tune for this hardware! Using stock or off-the-shelf EM with a 3-port solenoid installed in interrupt mode will result in overboosting!

A. Purpose

The benefits of this upgrade are faster spool, ability to hold higher boost, and better control over boost. A side benefit of the improved boost control is the ability to reach higher target boost levels in the low (1st and 2nd) gears.

B. Technical Background

A BCS is a binary device - i.e. it is either on (energized), or off. In the context of the Subaru device, when the BCS is energized, air is allowed to pass through the device, while when it is off, the air flow is cut.

There are two modes of boost controller operation, at least in this context: "bleed" mode, which is the mode that the stock BCS operates in, and "interrupt" mode, which is the mode that a 3-port BCS can operate in. Note that a 3-port BCS can also operate in "bleed" mode, depending on how it is connected.

Despite being digital in nature, these devices perform a very analog-like task, which is to control the boost level. In order to do so, the ECU opens and closes the solenoid at varying speeds, from 0 Hz (closed) to (effectively) ∞ Hz (open).

C. 2-Port Operation (Stock) Review

The stock solenoid is part of the stock bleed-based boost control system. See figure 1. When the solenoid is off (closed), pressurized air from the compressor is fed straight into the wastegate control. Any increase in compressor pressure beyond the rated pressure of the wastegate control results in the wastegate being opened, preventing buildup of boost.

When energized (opened), air is allowed to bleed off the compressor-to-wastegate line by way of a "T" connector (in stock vehicles, this air is vented back into the intake post-MAF). This prevents the wastegate from seeing the full compressor pressure, allowing boost to build. The '02-'03 (and some '04-'05) model years include a restrictor pill in the hose connecting the compressor to the "T" which meters the air for the stock ECU calibration.

While the stock system operates adequately, it can lead to problems at higher-than-stock boost levels. Since the bleed system is sized for the stock turbo at stock boost levels, it is typically incapable of correctly metering air at higher boost, allowing the wastegate to see pressure and open before intended. Additionally, since the wastegate is never completely cut off from seeing compressor pressure, it can open at low boost levels and inhibit boost buildup. Ideally, the wastegate should remain entirely closed for fastest boost buildup (as all exhaust is then forced through the turbine).

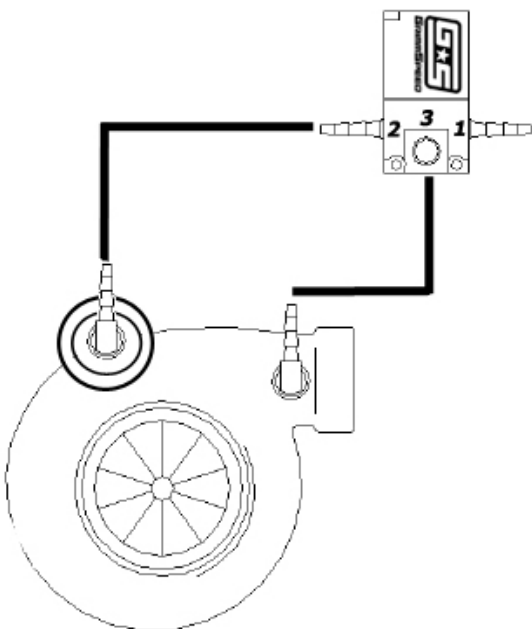

Figure 2: Pneumatic schematic for the GrimmSpeed Boost Control Solenoid

D. 3-Port Operation and Installation

A 3-port solenoid does away with the bleed-based system, explicitly shunting air from the compressor to the wastegate, or compressor to vent (or back into the intake post-MAF, OEM-style). Drawbacks of the bleed-

based system are thus eliminated, with the wastegate seeing literally no pressure when the solenoid is energized, to seeing all of the compressor pressure when the solenoid is de-energized.

Now able to explicitly control the opening and closing of the wastegate, the ECU is able to control boost with greater precision and reduced response time.

Installation for 2002-2005 WRX and 2004-2005 STI: Remove cover on passenger side engine bay exposing the factory boost control solenoid. Using a 10mm socket, remove factory solenoid and unplug the electrical connector and vacuum lines. Reuse the factory rubber mounts and transfer them to the GrimmSpeed bracket. Install GrimmSpeed bracket and solenoid while reusing the factory nuts.

Hook up vacuum lines. See Figure 2. Port 3 connects to a high-pressure boost source (there is a vacuum nipple on the turbo compressor outlet). Port 2 connects to the internal wastegate actuator vacuum nipple and Port 1 should be routed back to the intake (where the factory BCS mounts). Remove the factory restrictor pill. It is recommended that a plastic zip tie be used to secure vacuum lines. The electrical is plug and play with the supplied connector. Tuning: WGDC controls the actuator / turbo. Tuning to the WGDC is required (approx 30% reduction in WGDC)

Installation for 2006-2007 WRX and 2006-2007 STI: Remove factory boost control solenoid bracket on passenger side engine bay using 10mm wrench. Unplug the electrical connector and vacuum lines. The GrimmSpeed valve will go on the same bracket but in a different location on the bracket. You will use the two properly spaced holes to mount the GrimmSpeed valve. Attach using included grommets and hardware using a 10mm socket.

Hook up vacuum lines. See Figure 2. Port 3 connects to a high-pressure boost source (there is a vacuum nipple on the turbo compressor outlet). Port 2 connects to the internal wastegate actuator vacuum nipple and Port 1 should be routed back to the intake (where the factory BCS mounts). Remove the factory restrictor pill. It is recommended that a plastic zip tie be used to secure vacuum lines. The electrical is plug and play with the supplied connector. Tuning: WGDC controls the actuator / turbo. Tuning to the WGDC is required (approx 30% reduction in WGDC)

Installation for 2008+ WRX and 2005+ Legacy GT: For Legacy GTs, remove plastic engine cover. Remove factory boost control solenoid using a 10mm wrench. It is located on the passenger side of the intake manifold. Unplug the electrical connector and vacuum lines. Install GrimmSpeed bracket and solenoid while reusing the factory bolt.

Hook up vacuum lines. See Figure 2. Port 3 connects to a high-pressure boost source (there is a vacuum nipple on the turbo compressor outlet). Port 2 connects to the internal wastegate actuator vacuum nipple and Port 1 should be routed back to the intake (where the factory BCS mounts). Remove the factory restrictor pill. It is recommended that a plastic zip tie be used to secure vacuum lines. The electrical is plug and play with the supplied connector. Tuning: WGDC controls the actuator / turbo. Tuning to the WGDC is required (approx 30% reduction in WGDC)

Installation for 2008+ STI: Remove factory boost control solenoid using a 10mm wrench. It is located underneath the silver bracket mounted on the intake manifold. Unplug the electrical connector and vacuum lines. Install GrimmSpeed bracket and solenoid while reusing the factory bolt.

Hook up vacuum lines. See Figure 2. Port 3 connects to a high-pressure boost source (there is a vacuum nipple on the turbo compressor outlet). Port 2 connects to the internal wastegate actuator vacuum nipple and Port 1 should be routed back to the intake (where the factory BCS mounts). The factory restrictor pill can be removed for operation. It is recommended that a plastic zip tie is used to secure vacuum lines. The electrical is plug and play with the supplied connector. Tuning: WGDC controls the actuator / turbo. Tuning to the WGDC is required (approx 30% reduction in WGDC)

E. External Wastegate(EWG) Installation

Hook up vacuum lines. See Figure 3. Port 1 connects to a high-pressure boost source (there is a vacuum nipple on the turbo compressor outlet) and the bottom port on the external wastegate, you will need to use the factory "T" to connect . Port 2 connects to the top port on the external wastegate. The factory restrictor pill should be removed for operation. It is recommended that a plastic zip tie is used to secure vacuum lines. The electrical is plug and play with the supplied connector.

Figure 3. Pneumatic schematic for the GrimmSpeed Boost Control Solenoid with EWG

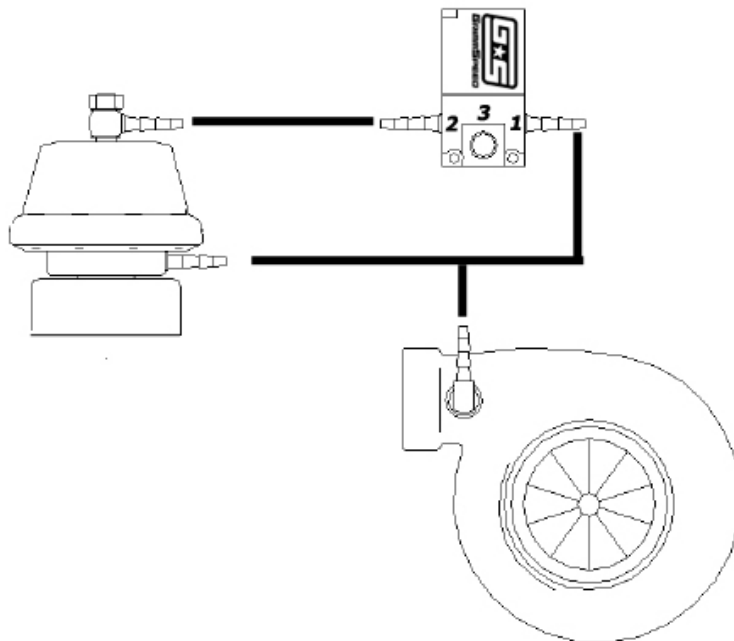

Please contact us if you have any questions during installation. 651.414.9747 or sales@grimmspeed.com.

Thank you for your purchase!

GrimmSpeed